

ACME[®]

Sapphire II

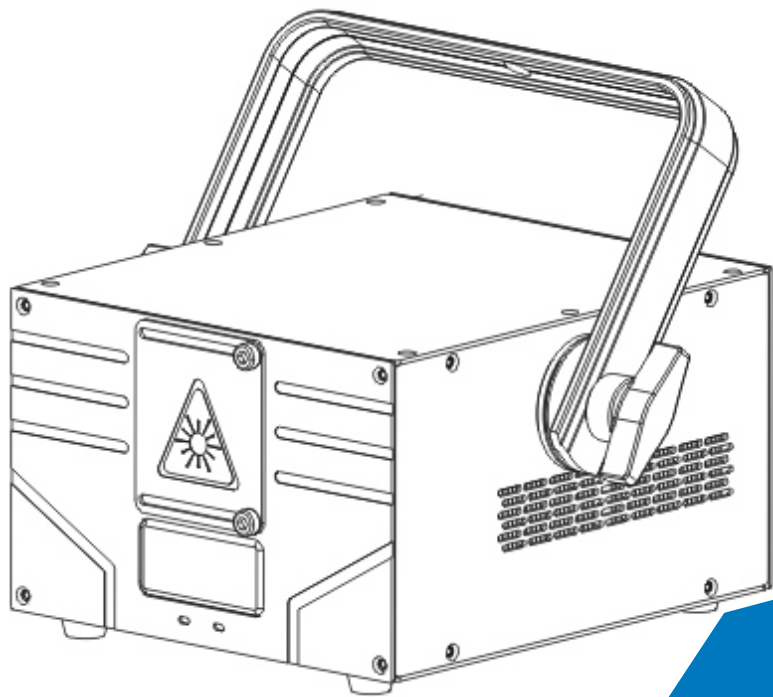

User Manual

Please read the instruction carefully before use

MENU

1. Safety Instructions	2
2. Technical Specifications	3
3. Installation	3
4. How to Set the Unit	4
4.1 Control Panel	4
4.2 Main Function.....	4
5. How to Control the Unit	6
6. DMX512 Configuration	7
7. DMX512 Connections	9
8. Troubleshooting.....	9
9. Fixture Cleaning	10

1. Safety Instructions



WARNING

Please read carefully the instruction, which includes important information about the installation, usage and maintenance.

**CAUTION - CLASS IV
LASER RADIATION WHEN OPEN
AVOID DIRECT EYE EXPOSURE**

- Please keep this User Guide for future consultation. If you sell the unit to another user, be sure that they also receive this instruction booklet.
- Unpack and check carefully there is no transportation damage before using the unit.
- Before operating, ensure that the voltage and frequency of power supply match the power requirements of the unit.
- It's important to ground the yellow/green conductor to earth in order to avoid electric shock.
- The unit is for indoor use only. Use only in a dry location.
- The unit must be installed in a location with adequate ventilation, at least 50cm from adjacent surfaces. Be sure that no ventilation slots are blocked.
- Disconnect main power before replacement or servicing.
- Make sure there are no flammable materials close to the unit while operating as it is fire hazard.
- Use safety cable when fixes this unit. DO NOT handle the unit by taking its head only, but always by taking its base.
- Maximum ambient temperature is T_a : 40°C. DO NOT operate it where the temperature is higher than this.
- Unit surface temperature may reach up to 85°C. DO NOT touch the housing bare-hand during its operation. Turn off the power and allow about 15 minutes for the unit to cool down before replacing or serving.
- In the event of serious operating problem, stop using the unit immediately. Never try to repair the unit by yourself. Repairs carried out by unskilled people can lead to damage or malfunction. Please contact the nearest authorized technical assistance center. Always use the same type spare parts.

- DO NOT touch any wire during operation as high voltage might be causing electric shock.

2. Technical Specifications

- Four control modes: ILDA / DMX/Sound Active/Auto Play;
- Voltage: AC100V~240V, 50/60Hz
- Laser power consumption: 5W
- Power consumption: 80W
- Scanning system: 40K Scanner
- Scanning angle: $\pm 40^\circ$
- Fuse: T 3.15A
- Dimension: 275X309X156 mm
- Weight: 7.6Kgs

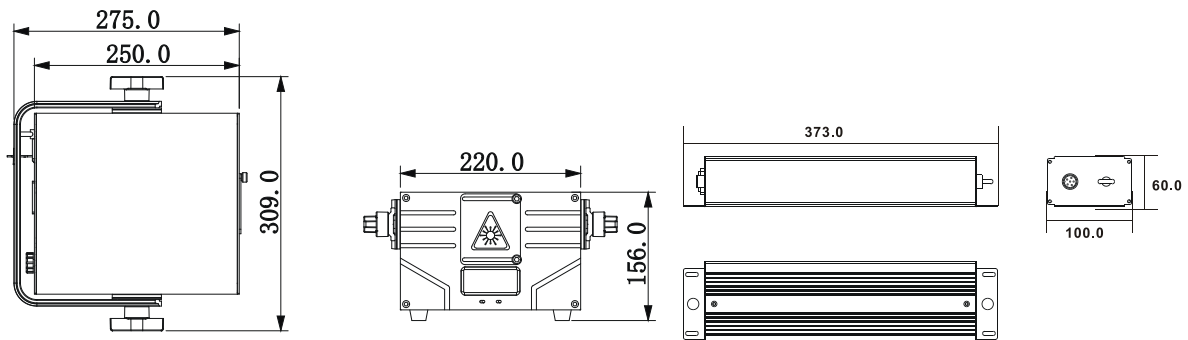

3. Installation

The unit should be mounted via its screw holes on the bracket. Always ensure that the unit is firmly fixed to avoid vibration and slipping while operating. And make sure that the structure to which you are attaching the unit is secure and is able to support a weight of 10 times of the unit's weight. Also always use a safety cable that can hold 12 times of the weight of the unit when installing the fixture.

The equipment must be fixed by professionals. And it must be fixed at a place where is out of the touch of people and has no one pass by or under it.

4. How to Set the Unit

4.1 Control Panel

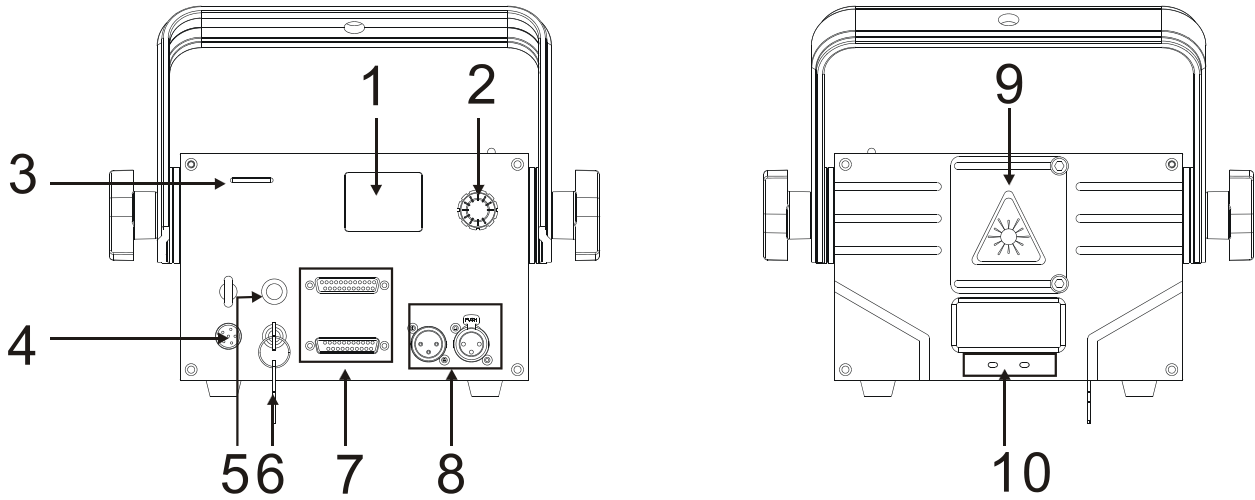

① OLED Display

② Knob

③ SD Card Port

④ Key Switch: The unit works when set RUN.

⑤ Power Input/output

⑥ Fuse

⑦ MIC

⑧ ILDA Port

⑨ DMX Input/Output

⑩ Power Indicator (Red); Laser Indicator (Green)

⑪ Light Output

4.2 Main Function

Turn the knob **PUSH/DIAL**, select any of the given functions, press the knob until the required function is

showing on the display. The main functions are shown overleaf:

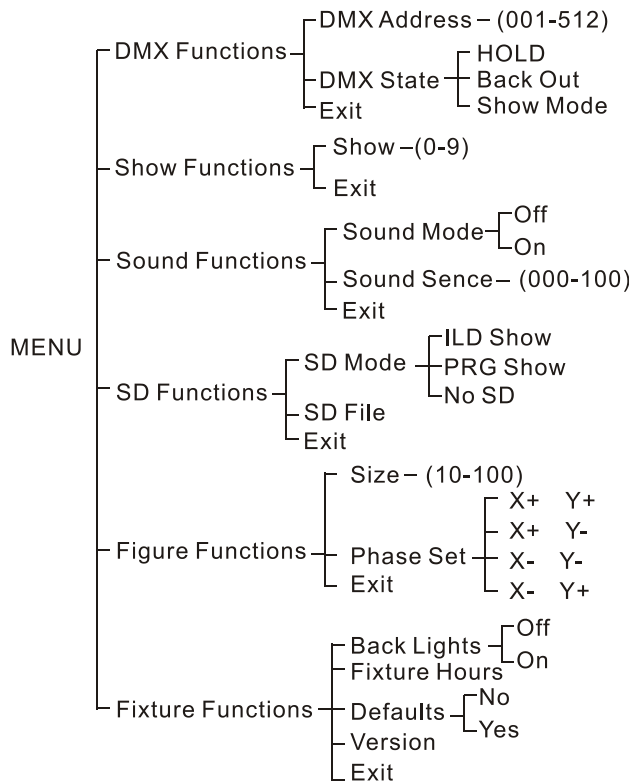

DMX Functions

Press the knob when the **DMX FUNCTIONS** show on the display, use the knob to select **DMX Address**, **DMX state** or **Exit**. Enter **DMX Address**, turn the knob to change the address, press the knob to confirm. Enter **DMX State**, select the **HOLD/Black Out/Show Mode**, when select Show Mode, the unit preference to sound active. If the sound active function is closed, the unit will auto run built-in show. ILDA signal control prior to DMX signal control. Press **EXIT** to back to the menu.

Show Functions

Press the knob when the **Show Functions** show on the display, use the knob to select **Show** or **Exit**. Enter **Show**, turn the knob to select show 0 to show 9, press the knob to confirm. (Show function only is valid when select Show Mode in DMX functions.) SD card show prior to built-in show. Press **EXIT** to back to the menu.

Sound Functions

Press the knob when the **Sound Functions** show on the display, use the knob to select **Sound Mode** or **Sound Sense** or **Exit**. Enter **Sound Mode**, use the knob to select On or off, press the knob to confirm. ILDA signal and DMX signal control prior to sound active mode. Press **EXIT** to back to the menu.

SD Functions

Press the knob when the **SD Functions** show on the display, use the knob to select **SD Mode, SD File** or **Exit**. Enter **SD Mode**, use the knob to select ILD Show, PRG Show or No SD, press the knob to confirm. Enter **SD File**, select the file or folder, press the knob to confirm. Press **EXIT** to back to the menu.

Figure Functions

Press the knob when the **Figure Functions** show on the display, use the knob to select **Size, Phase Set** or **Exit**. Enter **Size**, use the knob to select figure size from 10 to 100, press the knob to confirm. Enter **Phase Set**, set the position of the figure. Press **EXIT** to back to the menu.

Fixture Functions

Press the knob when the **Fixture Functions** show on the display, use the knob to select **Back Lights, Fixture Hours, Defaults, Version** or **Exit**. Enter **Back lights**, use the knob to select on or off, press the knob to confirm. Enter **Fixture Hours**, the running time of the unit will be show on the display. Enter **Defaults**, use the knob to select Yes or no to restore factory settings or not. Enter **Version**, the version of the software will be show on the display. Press **EXIT** to back to the menu.

5. How to Control the Unit

1. By ILDA;

Connect the unit to the computer with ILDA wire and control the software by computer laser;

Priority to control the unit: ILDA > DMX > Sound active > Auto play

2. By universal DMX controller;

Set the DMX address, the unit will be ready to receive DMX signal.

3. Sound active;

The unit will run show by the sound active.

4. Auto play;

The unit will auto play when no signal.

6. DMX512 Configuration

DMX Channel:

Channel	Value	Function	
1	Choose Mode	0-9	Blackout
		10-49	PRG Mode
		50-99	ILD Mode
		100-149	Sound active Mode
		150-199	Auto play Mode
		200-255	Manual Mode
2	Pattern/File Select	0-255	Manual Mode PRG/ILD Mode
			Pattern change (Change pattern every 3 values) Select file
3	Strobe/File Select	0-10	No strobe
		11-255	Auto strobe
4	Pan Moving	0-125	Position select
		126-155	Repeat moving from left to right
		156-185	Repeat moving from right to left
		186-225	Repeat moving from left to right
		226-245	Auto play
		246-255	Sound active play
5	Tilt Moving	0-125	Position select
		126-155	Repeat moving from left to right
		156-185	Repeat moving from right to left
		186-225	Repeat moving from left to right
		226-245	Auto play
		246-255	Sound active play
6	Zoom	0-10	No effect
		11-87	Manual adjust
		188-150	Zoom in
		151-200	Zoom out
		201-255	Repeat zooming
7	Pan Rotation	0	No rotation
		1-128	Manual adjust
		129-255	Auto rotation
8	Tilt Rotation	0	No rotation
		1-128	Manual adjust
		129-255	Auto rotation
9	Centre Rotation	0	No rotation
		1-128	Manual adjust
		129-192	Counter-clockwise rotation

		193-255	Clockwise rotation
10	Slow Drawing	0-11	No function
		12-74	Manual adjust
		75-104	Auto slow drawing from slow to fast
		105-144	Auto slow drawing from fast to slow
		145-184	Repeat slow drawing
		185-224	Repeat slow drawing from slow to fast end to end
		225-255	Repeat slow drawing from fast to slow end to end
11	Pan Waving	0-10	No function
		11-69	Small wave
		70-129	Middle wave
		130-189	Big wave
		190-255	The biggest wave
12	Tilt Waving	0-10	No function
		11-69	Small wave
		70-129	Middle wave
		130-189	Big wave
		190-255	The biggest wave
13	Show Mode	0-63	Normal Show Mode
		64-127	Light spot Show Mode
		128-191	Division Show Mode
		192-255	Spot Show Mode
14	Color		
	RGB	0-16	White
		17-33	Red
		34-50	Green
		51-67	Blue
		68-84	Yellow
		85-101	Purple
		102-118	Cyan
		119-135	White/Red/Green/Blue division
		136-152	Blue/Yellow/Purple/Cyan division
		153-169	White/Red/Green/Blue/Yellow/Purple/Cyan division
		170-186	White/Red/Green/Blue flow
		187-203	Blue/Yellow/Purple/Cyan flow
		204-220	White/Red/Green/Blue/Yellow/Purple/Cyan flow
		221-237	Division show according to the breakpoint
238-255	Sound active change color		
15	R Dimmer	0-5	Full light
		6-255	Bright to dim
16	G Dimmer	0-5	Full light
		6-255	Bright to dim
17	B Dimmer	0-5	Full light
		6-255	Bright to dim

7. DMX512 Connections

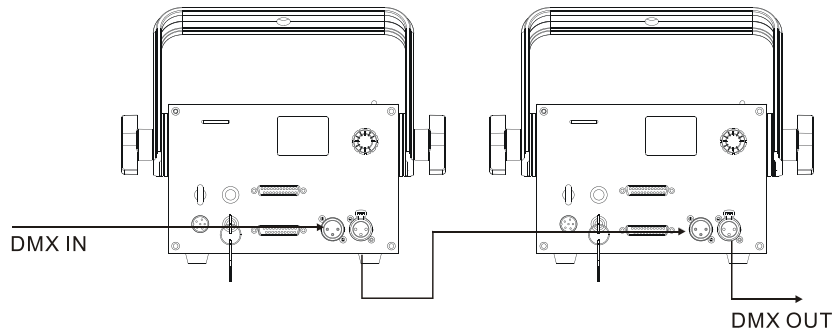

1. If you using a controller with 5 pins DMX output, you need to use a 5 to 3 pin adapter-cable.
2. Connect the unit together in a `daisy chain` by XLR plug from the output of the unit to the input of the next unit. The cable can not branched or split to a `Y` cable. DMX 512 is a very high-speed signal. Inadequate or damaged cables, soldered joints or corroded connectors can easily distort the signal and shut down the system.
3. The DMX output and input connectors are pass-through to maintain the DMX circuit, when one of the units' power is disconnected.
4. Each lighting unit needs to have an address set to receive the data sent by the controller. The address number is between 0-511 (usually 0 & 1 are equal to 1).
5. The end of the DMX 512 system should be terminated to reduce signal errors.
6. 3 pin XLR connectors are more popular than 5 pin XLR.

3 pin XLR: Pin 1: GND, Pin 2: Negative signal (-), Pin 3: Positive signal (+)

5 pin XLR: Pin 1: GND, Pin 2: Negative signal (-), Pin 3: Positive signal (+), Pin 4/Pin 5: Not used.

8. Troubleshooting

Following are a few common problems that may occur during operation. Here are some suggestions for easy troubleshooting:

A. The unit does not work, no light and the fan does not work

1. Check the connection of power and main fuse.

2. Measure the mains voltage on the main connector.
3. Check the power on LED.

B. Not responding to DMX controller

1. DMX LED should be on. If not, check DMX connectors, cables to see if link properly.
2. If the DMX LED is on and no response to the channel, check the address settings and DMX polarity.
3. If you have intermittent DMX signal problems, check the pins on connectors or on PCB of the unit or the previous one.
4. Try to use another DMX controller.
5. Check if the DMX cables run near or run alongside to high voltage cables that may cause damage or interference to DMX interface circuit.

C. One of the channels is not working well

1. The stepper motor might be damaged or the cable connected to the PCB is broken.
2. The motor's drive IC on the PCB might be out of condition.

9. Fixture Cleaning

The cleaning of internal and external optical lenses and/or mirrors must be carried out periodically to optimize light output. Cleaning frequency depends on the environment in which the fixture operates: damp, smoky or particularly dirty surrounding can cause greater accumulation of dirt on the unit's optics.

- Clean with soft cloth using normal glass cleaning fluid.
- Always dry the parts carefully.
- Clean the external optics at least every 20 days. Clean the internal optics at least every 30/60 days.

Innovation, Quality, Performance