

9. Fixture Cleaning

The cleaning of internal must be carried out periodically. Cleaning frequency depends on the environment in which the fixture operates: damp, smoky or particularly dirty surrounding can cause greater accumulation of dirt.

- Clean with soft cloth using normal glass cleaning fluid.
- Always dry the parts carefully.
- Clean the external at least every 20 days.



Innovation, Quality, Performance

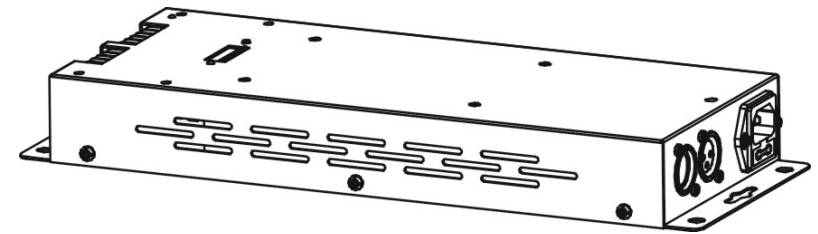

LED-HC101 II

User Manual

Please read the instructions carefully before use

TABLE OF CONTENTS

1. Safety Instructions
2. Technical Specifications
3. Function
4. Installation
5. DMX512 Address setting
6. How to control the fixture
7. DMX 512 Connection
8. Troubleshooting
9. Fixture Cleaning

8. Troubleshooting

Following are a few common problems that may occur during operation. Here are some suggestions for easy troubleshooting:

A. The fixture does not work

1. Check the connection of power and main fuse.
2. Measure the mains voltage on the main connector.

B. Not responding to DMX controller

1. DMX LED should be on. If not, check DMX connectors and cables to see if link properly.
2. If the DMX LED is on and no response to the channel, check the address settings and DMX polarity.
3. If you have intermittent DMX signal problems, check the pins on connectors or on PCB of the fixture or the previous one.
4. Try to use another DMX controller.
5. Check if the DMX cables run near or run alongside to high voltage cables that may cause damage or interference to DMX interface circuit.

C. No response to the sound

1. Make sure the fixture does not receive DMX signal.
2. Check microphone to see if it is good by tapping the microphone.

7. DMX512 Connection

The DMX 512 is widely used in intelligent lighting control, with a maximum of 512 channels.

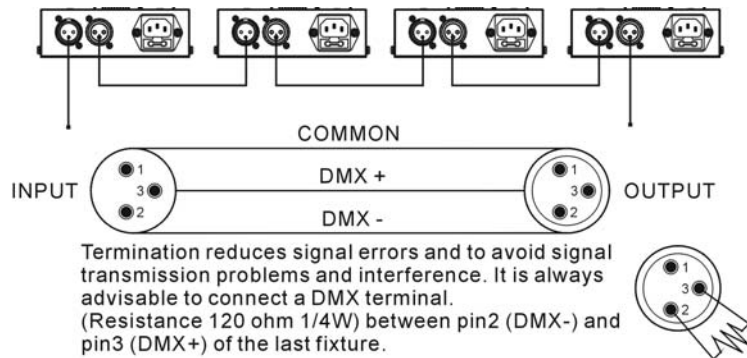

1. If you using a controller with 5 pins DMX output, you need to use a 5 to 3 pin adapter-cable.
2. At last unit, the DMX cable has to be terminated with a terminator. Solder a 120 ohm 1/4W resistor between pin 2(DMX-) and pin 3(DMX+) into a 3-pin XLR-plug and plug it in the DMX-output of the last unit.
3. Connect the unit together in a `daisy chain` by XLR plug from the output of the unit to the input of the next unit. The cable can not branched or split to a `Y` cable. DMX 512 is a very high-speed signal. Inadequate or damaged cables, soldered joints or corroded connectors can easily distort the signal and shut down the system.
4. The DMX output and input connectors are pass-through to maintain the DMX circuit, when one of the units' power is disconnected.
5. Each lighting unit needs to have an address set to receive the data sent by the controller. The address number is between 0-511 (usually 0 & 1 are equal to 1).
6. The end of the DMX 512 system should be terminated to reduce signal errors.
7. 3 pin XLR connectors are more popular than 5 pin XLR.
3 pin XLR: Pin 1: GND, Pin 2: Negative signal (-), Pin 3: Positive signal (+)
5 pin XLR: Pin 1: GND, Pin 2: Negative signal (-), Pin 3: Positive signal (+)

1. Safety Introductions



WARNING

Please read the instructions carefully which includes important information about the installation, operation and maintenance.

- Please keep this User Manual for future consultation. If you sell the fixture to another user, be sure that they also receive this instruction booklet.
- Unpack and check carefully there is no transportation damage before using the fixture.
- Before operating, ensure that the voltage and frequency of power supply match the power requirements of the fixture.
- Disconnect mains power before servicing and maintenance.
- In the event of serious operating problem, stop using the fixture immediately. Never try to repair the fixture by yourself. Repairs carried out by unskilled people can lead to damage or malfunction. Please contact the nearest authorized technical assistance center. Always use the same type spare parts.
- Do not touch any wire during operation and there might be a hazard of electric shock.
- To prevent or reduce the risk of electrical shock or fire, do not expose the fixture to rain or moisture.
- There are no user serviceable parts inside the fixture. Do not open the housing or attempt any repairs by yourself. In the unlikely event your fixture may require service, please contact your nearest dealer.

2. Technical Specifications

- A compact LED controller for all kinds of DC 24V passive RGB Fixtures.
- Come with switch power supply inside
- Built-in programs under Master/Slave mode triggered by music.
- 4 different ways of DMX addressing
- Terminals for linking LED-Wall Dimmer, and it provides power to LED Wall Dimmer.
- **Power input:** 120-240V~50/60Hz
- **Power output:** DC 24V
- **Max Load :** 100W
- **Channels**
Channel 1 = Red
Channel 2 = Green
Channel 3 = Blue
Channel 4 = Dimmer / Strobe
- **Dimension :** 356 x 132 x 43 mm
- **Weight :** 2kg

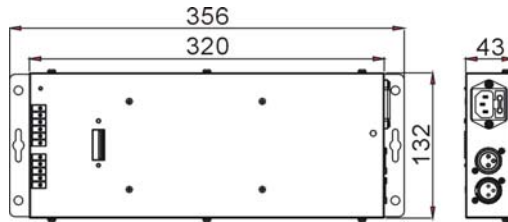

3. Function

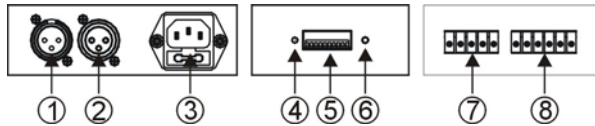

1. **DMX INPUT:** input DMX signal
2. **DMX OUTPUT:** output DMX signal
3. **POWER SOCKET:** for power input
4. **LED:** show the status of the unit
5. **DIP SWITCH:** used to set the start address of the unit or choose functions
6. **AUTO DMX ADDRESS:** used to set start address automatically.
7. **LED-WD CONNECTOR:** used to receive the signal of LED-WD only
8. **SIGNAL OUTPUT:** output signal and power for light

DMX512 Configuration			
Ch1	Ch2	Ch3	Ch4
RED	GREEN	BLUE	DIMMER/STROBE
255 100%	255 100%	255 100%	248-255 OPEN
0 0%	0 0%	0 0%	201-247
			191-200 SOUND CHASE
			8-190
			0-7 CLOSED

C. Master/Slave operation

The fixture will allow you to link 16 fixtures together and operate without a controller. In Master/Slave mode, the first fixture will control the others to give an automatic, sound activated, synchronized light show. This function is good when you want an instant show. The first fixture its DMX input cable will have nothing connect it, and the other fixtures will be set in slave mode automatically. Their DMX input cables connect the last fixture DMX output cable (daisy chain). Any fixture can act as a Master or as a Slave

6. How to control the fixture

There are three ways to control the fixture

- A. Control by DIP switches
- B. Control by Universal DMX controller
- C. Master/Slave operation

A. Control by DIP switches

Dip switches setting	Mode
	Master
	Slave
	Sound
	Chase Use Dip switch 3, 4, 5 to choose chase speed (1-8)
	Fade Use Dip switch 3, 4, 5 to choose fade speed (1-8)
	Color Use Dip switch 6, 7, 8, 9 to choose color (16)

B. Control by universal DMX controller

If you use a controller with 5 pins DMX connector, you need to use a 5 to 3 pin adapter. The fixture uses four channels. Please refer to the following diagram to use your controller to activate the fixture.

4. Installation

1. Ensure that mains power supply is off before installing or wiring the LED fixture
2. Unscrew the screws and connect the wires as diagrams below
3. Tight the screws.

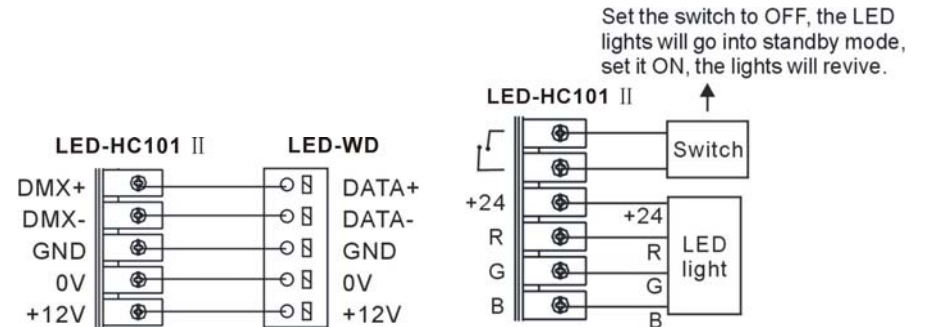

CAUTIONS : the LED controller total output power consumption is 100 watt.

5. DMX512 Address Setting

Each fixture needs to have a start address set to receive the data sent by the controller. The address number is between 0-511 (usually 0 & 1 are equal to 1). The address, also know as the start channel, is the first channel used to receive instructions from the controller.

There are four ways to set the fixture DMX start address:

- A. DMX address setting by dip-switches
- B. Auto DMX addressing
- C. Remote DMX address setting by CA-T DMX TESTER
- D. Remote DMX address setting by universal DMX controller

*** If you use the function B, C or D to set the DMX start address, the fixtures of the chain all DIP switch MUST be set to OFF.**

*** When you set the address by DMX controller and dip-switch at the same time, the order of the DMX controller will be invalid.**

A. DMX address setting by dip-switches

1. Set the start address by dip-switch as the diagram below
2. Hold the AUTO DMX ADDRESS button for about 5 seconds, the LED lights blinking indicating the address is set successfully.

Dip	# 1	# 2	# 3	# 4	# 5	# 6	# 7	# 8	# 9	# 10
Value	1	2	4	8	16	32	64	128	256	Master/Slave

• Examples:

Channel 01 : dip / on : # 1 (=1)

Channel 05 : dip / on : # 1, # 3 (1+4=5)

Channel 09 : dip / on : # 1, # 4 (1+8=9)

Channel 13 : dip / on : # 1, # 3, # 4 (1+4+8=13)

B. Auto DMX addressing

1. The DMX address of fixture can be set automatically. Set all dip-switches to OFF and hold the AUTO DMX ADDRESS button of the first unit for about 5 seconds, the fixture will be set the DMX start address to 1, and the other fixtures of the chain will be set their own DMX start address automatically.
2. The LED fixtures use four channels, the next fixture's will be automatic calculate their own DMX address, not need to calculate the DMX channels of each fixture in the chain. (Fixture 1 = 1, Fixture 2 = 5, Fixture 3 = 9, Fixture 4 = 13, Fixture...)
3. No need to turn the fixture off when you change the DMX address, as new DMX address setting will be effect at once. Every time you turn the fixture on, it will be ready to receive DMX signal or run the built-in programs.

C. Remote DMX address setting by CA-T DMX TESTER

The fixture can be set the DMX address remotely by CA-T *DMX TESTER*. Please refer to the CA-T user manual to set the DMX address to the fixture.

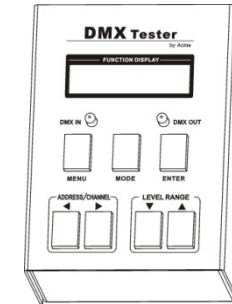
**D. Remote DMX address setting by universal DMX controller**

- Make sure the DMX cables of all units are connected.
- Connect the first unit to a universal DMX controller.
- Connect all units to the mains so they are switched on.
- Set all DMX-channels on your DMX-controller to zero (value 000).
- Set the DMX-channel, that you want to assign as DMX start address on you unit, to maximum (value 255).
- Press the "Auto DMX address" button on the unit shortly.
- If you want to set another unit to the same DMX start address, simply press it's "Auto DMX address" button and it will receive the same address.
- Done!

An example to make things clear:

- We will set the DMX start address of a unit to 106:
- Connect the unit to the DMX-controller as described above and make sure all is switched on.
- Set all DMX-channels on the controller to zero (000).
- Now set DMX-channel 106 to maximum (255).
- Press the "Auto DMX address" button on the unit shortly.
- Done! Your unit now has DMX address 106!