

BW-54-3VW DXX IV

User Manual

Please read the instructions carefully before use

Innovation, Quality, Performance

CONTENTS

1. Safety Instructions.....	2
2. Technical Specifications	4
3. How To Set The Fixture.....	5
3.1 Control Panel.....	5
3.2. Main Functions.....	6
4.How To Control The Unit.....	10
4.1 Master/Slave Built In Preprogrammed Function.....	10
4.2 DMX Controller.....	10
4.3 DMX 512 Configuration.....	11
4.4 DMX512 Connection	12
5. Troubleshooting.....	13
6. Fixture Cleaning	13

Declaration of Conformity

We declare that our products (lighting equipments) comply with the following specification and bears CE mark in accordance with the provision of the Electromagnetic Compatibility (EMC) Directive 89/336/EEC.

EN55103-1: 2009 ; EN55103-2: 2009; EN62471: 2008;
EN61000-3-2: 2006 + A1:2009 + A2:2009; EN61000-3-3: 2008.

& Harmonized Standard

EN60598-2-17:1989 + A2:1991; EN60598-1:2008+ A11: 2009

EN 62471:2008; EN 62493: 2010

Safety of household and similar electrical appliances

Part 1: General requirements

5. Troubleshooting

Following are a few common problems that may occur during operation. Here are some suggestions for easy troubleshooting:

A. The unit does not work, no light and the fan does not work

1. Check the connection of power and main fuse.
2. Measure the mains voltage on the main connector.

B. Not responding to DMX controller

1. DMX LED should be on. If not, check DMX connectors, cables to see if link properly.
2. If the DMX LED is on and no response to the channel, check the address settings and DMX polarity.
3. If you have intermittent DMX signal problems, check the pins on connectors or on PCB of the unit or the previous one.
4. Try to use another DMX controller.
5. Check if the DMX cables run near or run alongside to high voltage cables that may cause damage or interference to DMX interface circuit.

6. Fixture Cleaning

The cleaning of internal must be carried out periodically to optimize light output. Cleaning frequency depends on the environment in which the fixture operates: damp, smoky or particularly dirty surrounding can cause greater accumulation of dirt on the fixture's optics.

- Clean with soft cloth using normal glass cleaning fluid.
- Always dry the parts carefully.
- Clean the external optics at least every 20 days.

1. Safety Instructions



WARNING

Please read the instructions carefully which include important information about the installation, operation and maintenance.

- Please keep this User Guide for future consultation. If you sell the unit to another user, be sure that they also receive this instruction booklet.

Caution:

- All fixtures are intact from the manufacturer, please operate follow up the user manual, artificial fault are not under guarantee repair.
- Unpack and check carefully there is no transportation damage before using the unit.
- The unit is for indoor use only. Use only in a dry location.
- Do install and operate by operator.
- Use safety chain when fixes the unit.
- The unit must be installed in a location with adequate ventilation, at least 50cm from adjacent surfaces.
- Be sure that no ventilation slots are blocked, otherwise the unit will be overheated.
- Before operating, ensure that the voltage and frequency of power supply match the power requirements of the unit.
- It's important to ground the yellow/green conductor to earth in order to avoid electric shock.
- Maximum ambient temperature TA : 40°C. Don't operate it where the temperature is higher than this.
- Don't connect the device to any dimmer pack.
- First run, there will be smoke or smells, and all disappearing a few minutes later.
- Make sure there are no flammable materials close to the unit while operating, as it is fire hazard.
- Look over power wires carefully, replace immediately if there is any damage.
- Unit surface temperature may reach up to 60°C. Don't touch the housing bare-hand during its operation.
- Never run on for a long time lest shortening lifespan.
- Avoid any inflammable liquids, water or metal objects entering the unit. Once it happen, cut off the mains power immediately.

- Do not operate in dirty and dusty environment, also cleaning fixtures regularly.
- Do not allow children to operate the fixture.
- Do not touch any wire during operation as there might be a hazard of electric shock.
- Avoid power wires together arounding other cables.
- Replace fuse only with the same type.
- In the event of serious operating problem, stop using the unit immediately.
- Never turn on and off the unit time after time.
- The housing, the lenses, or the ultraviolet filter must be replaced if they are visibly damaged.
- Do not open the unit as there are no user serviceable parts inside. Never try to repair the unit by yourself. Repairs carried out by unskilled people can lead to damage or malfunction. Please contact the nearest authorized technical assistance center.
- Disconnect the mains power if the fixture is not used for a long time.
- Do use original packing materials once transport it again.
- To prevent or reduce the risk of electrical shock or fire, do not expose the unit to rain or moisture.
- Do not look directly at the LED light beam while the fixture is on.
- To protect the machine, power off 10s rear can electrify.

Installation

The unit should be mounted via its screw holes on the bracket. Always ensure that the unit is firmly fixed to avoid vibration and slipping while operating. Always ensure that the structure to which you are attaching the unit is secure and is able to support a weight of 10 times of the unit's weight. Also always use a safety cable that can hold 12 times of the weight of the unit when installing the fixture.

The equipment must be fixed by professionals. And it must be fixed at a place where is out of the touch of people and has no one pass by or under it.

4.4 DMX512 Connection

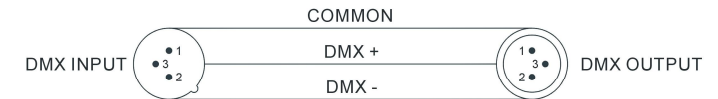
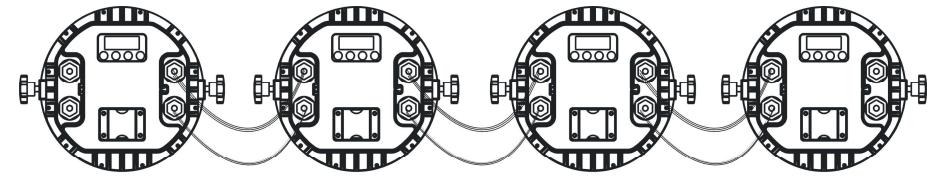

Termination reduces signal errors and voids signal transmission problems and interference. It is always advisable to connect a DMX terminal. (Resistance 120 ohm 1/4W) between pin2(DMX-) and pin3(DMX+) of the last fixture.



1. If you using a controller with 5 pins DMX output, you need to use a 5 to 3 pin adapter-cable.
2. At last unit, the DMX cable has to be terminated with a terminator. Solder a 120 ohm 1/4W resistor between pin 2(DMX-) and pin 3(DMX+) into a 3-pin XLR-plug and plug it in the DMX-output of the last unit.
3. Connect the unit together in a `daisy chain` by XLR plug from the output of the unit to the input of the next unit. The cable can not branched or split to a `Y` cable. DMX 512 is a very high-speed signal. Inadequate or damaged cables, soldered joints or corroded connectors can easily distort the signal and shut down the system.
4. The DMX output and input connectors are pass-through to maintain the DMX circuit, when one of the units' power is disconnected.
5. Each lighting unit needs to have an address set to receive the data sent by the controller. The address number is between 0-511 (usually 0 & 1 are equal to 1).
6. The end of the DMX 512 system should be terminated to reduce signal errors.
7. 3 pin XLR connectors are more popular than 5 pin XLR.
 - 3 pin XLR: Pin 1: GND, Pin 2: Negative signal (-), Pin 3: Positive signal (+)
 - 5 pin XLR: Pin 1: GND, Pin 2: Negative signal (-), Pin 3: Positive signal (+), Pin 4/Pin 5: Not used.

Please refer to the following diagram to address your DMX512 channel for the first 4 units:



4.3 DMX 512 Configuration

DMX512 Configurations			
2CH(2 Mode)		2CH(2D Mode)	
Ch1	Ch2	Ch1	Ch2
CW	VW	CW VW	Dimmer

2. Technical Specifications

- **Light source:** 3W LED x 54pcs
- **Voltage:** AC 100-240V/50HZ
- **Power consumption:** 145W
- **Lens Option:** D6, D15, D25, D30, D40, D60, D80
- **Dimension:** 300.6 x 229 x 340 mm
- **Weight:** 9.2 kg
- **Power Cord Daisy Chain:** 14 Fixtures Max. (230V)
7 Fixtures Max. (120V)
- **DMX Signal Daisy Chain:** 64 Fixtures Max.

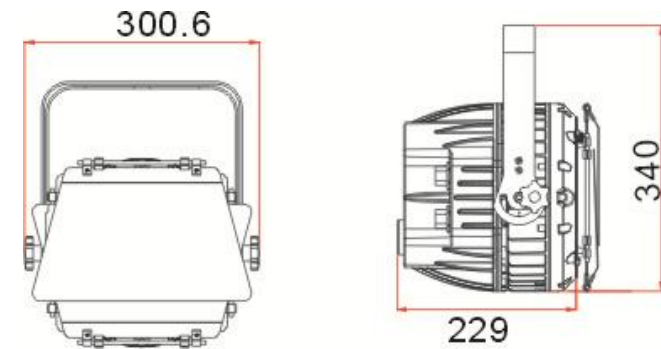

3. How To Set The Fixture

3.1 Control Panel

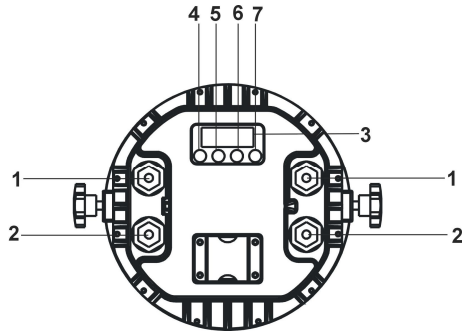

1: Power

Water proof connectors for power input/output

2: DMX input/output

Water proof connectors for DMX 512 operation, 3-pin XLR cable to link the units together

3: Display

To show the menu and the selected functions

Button:

4	MENU	To select the programming functions
5	DOWN	To go backward in the selected functions
6	UP	To go forward in the selected functions
7	ENTER	To confirm the selected functions

Firmware Version

Press the **MENU** button up to when the  is blinking on the display. Press the **ENTER** button and the display will show the software version of the unit. To go back to the main functions press the **MENU** button again.



4.How To Control The Unit

You can operate the unit in two ways:

1. By master/slave built-in preprogram function
2. By DMX controller

No need to turn the unit off when you change the DMX address, as new DMX address setting will be effected at once. Every time you turn the unit on, it will show  on the display and move all the motors to their 'home' position. After that the unit will be ready to receive DMX signal or run the built in programs.

4.1 Master/Slave Built In Preprogrammed Function

By linking the units in master/slave connection, the first unit will control the other units to give an automatic, sound activated, synchronized light show. This function is good when you want an instant show. You have to select  (show 1) or  (show 2)or  (show 19, show17~19 have to be edited by the user) show for the first unit. Its DMX input jack will have nothing plugged into. The other units will be slave mode automatically.

4.2 DMX Controller

Use universal DMX controller to control the units, you have to set DMX address from 1 to 512 channel so that the units can receive DMX signal.

Press the **MENU** button up to when the  is showing on the display. Press the **ENTER** button and the display will blink. Use the **DOWN** and **UP** button to change the DMX512 address. Once the address has been selected, press and keep the **ENTER** button pressed up to when the display stops blinking or storing automatically 8 seconds later. To go back to the functions without any change press the **MENU** button again.

Loc Keyboard Lock

Press the **MENU** button until **Loc** is blinking on the display. Use the **ENTER** button to change the display mode between **no** (the keyboard is unlocked.) and **GPS** (the keyboard is locked.). To go back to the main functions press the **MENU** button.

TEST Auto Test

Press the **MENU** button up to when the **TEST** is blinking on the display. Press the **ENTER** button and the unit will run the built-in programmer for self-test. To go back to the main functions press the **MENU** button.

LED LED Display

Press the **MENU** button up to when the **LED** is shown on the display. Press the **ENTER** button and the display will blink. Use the **DOWN** and **UP** button to select the **on** (LED display always on) or **off** (LED display off one minute after exit menu mode). Once select, press the **ENTER** button to store (or automatically exit menu mode after idling one minute). To go back to the main functions press the **MENU** button.

TEMP Temperature

Press the **MENU** button up to when the **TEMP** is blinking on the display. Press the **ENTER** button and the display will show the temperature of the unit (7 Hours). To go back to the main functions press the **MENU** button.

Fhrs Fixture Hours

Press the **MENU** button up to when the **Fhrs** is blinking on the display. Press the **ENTER** button and the display will show the number of working hours of the unit(7 Hours). To go back to the main functions press the **MENU** button.

3.2. Main Functions

To select any functions, press **MENU** button until the required one is shown on the display. Select the function by **ENTER** button and the display will blink. Use **DOWN** and **UP** button to change the mode. Once the required mode has been selected, press **ENTER** button to setup or it will automatically return to the main functions without any change after idling one minute. Back to the functions without any change press **MENU** button. The main functions are shown below:

Once you set **Loc** to **GPS**, after running in show mode for 5 minutes without any change or restarting the unit, the key board become locked. Press **ENTER** button to enable the menu, the display will show **000**, press **UP** and **DOWN** button until it shows **111**, then press **ENTER** to unlock.

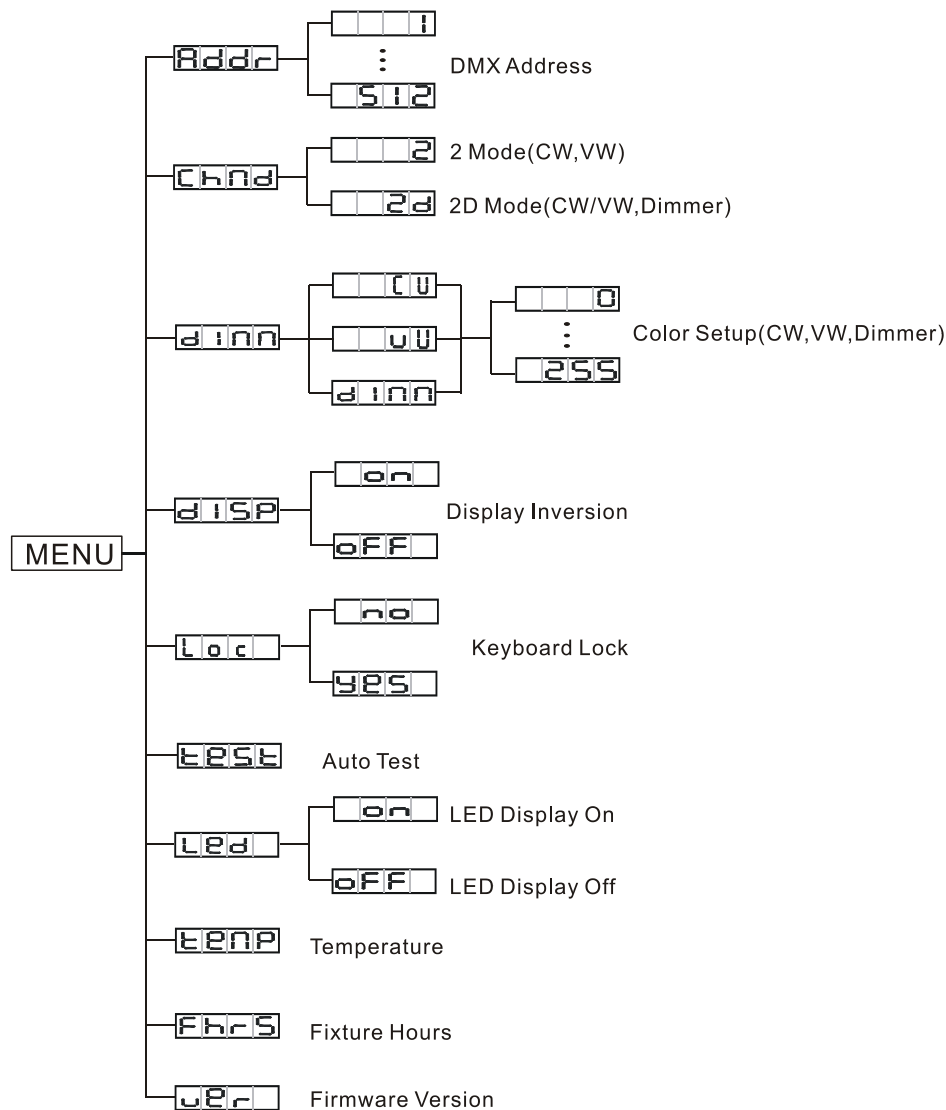

Addr DMX Address

Press the **MENU** button up to when the **Addr** is shown on the display. Press the **ENTER** button and the display will blink. Use the **DOWN** and **UP** button to change the DMX 512 address. Once the address has been selected, press the **ENTER** button to setup (or automatically exit menu mode after idling one minute). To go back to the main functions press the **MENU** button.

Chnd Channel Mode

Press the **MENU** button up to when the **Chnd** is shown on the display. Press the **ENTER** button and the display will blink. Use the **DOWN** and **UP** button to select the **2** (2 Mode: CW,VW) or **2d** (2D Mode: CW/ VW, Dimmer) mode. Once the mode has been selected, press the **ENTER** button to setup (or automatically exit menu mode after idling one minute). To go back to the main functions press the **MENU** button.

dinn Color Setup

Press the **MENU** button up to when the **dinn** is shown on the display. Press the **ENTER** button and the display will blink. Use the **DOWN** and **UP** button to select the **00** (Cool White), **00** (Warm White) or **dinn** (Dimmer). Once the function has been selected, press the **ENTER** button, then press the **DOWN** and **UP** button to adjust the value from 0 to 255, and press the **ENTER** button to save. To go back to the main functions press the **MENU** button.

DISP Display Inversion

Press the **MENU** button until **DISP** is blinking on the display. Use the **ENTER** button to change the display mode between **off** (display normal) and **on** (display inverse). To go back to the main functions press the **MENU** button.