

Declaration of Conformity

We declare that our products (lighting equipments) comply with the following specification and bears CE mark in accordance with the provision of the Electromagnetic Compatibility (EMC) Directive 89/336/EEC.

EN55103-1: 2009 ; EN55103-2: 2009; EN62471: 2008;
EN61000-3-2: 2006 + A1:2009 + A2:2009; EN61000-3-3: 2008.

&

Harmonized Standard

EN 60598-1:2008 + All:2009; EN 60598-2-17:1989 + A2:1991;
EN 62471:2008; EN 62493: 2010
Safety of household and similar electrical appliances
Part 1: General requirements

Innovation, Quality, Performance

ACME®

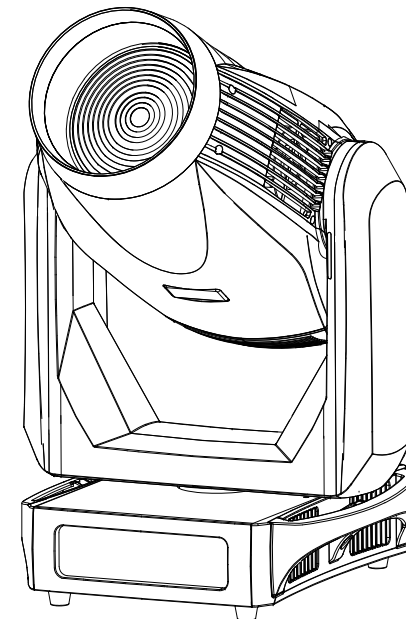

XP-1000WZ

User Manual

Please read the instruction carefully before use

TABLE OF CONTENTS

1. Safety Instruction	2
2. Technical Specification.....	3
3. Control Panel	5
4. Lamp.....	6
4.1 Lamp	6
4.2 Change The Lamp	7
5. How To Set The Unit	8
5.1 Main Function	8
5.2 Home Position Adjustment.....	16
5.3 Error Information.....	19
6. Control By Universal DMX Controller.....	20
6.1 DMX Connections	20
6.2 Channel Mode Setting	21
6.3 Address Setting.....	21
6.4 DMX Control	22
7. Troubleshooting.....	30
8. Check、 Cleaning and Maintenance Schedule.....	32

B

Code	
R	Replace
C	Clean
L	Lubricate
A	Adjust

Cleaning:

The cleaning of internal and external optical lenses and/or mirrors must be carried out periodically to optimize light output. Cleaning frequency depends on the environment in which the fixture operates: damp, smoky or particularly dirty surrounding can cause greater accumulation of dirt on the unit's optics.

- Clean with soft cloth and use normal glass to clean liquid.
- Always dry the parts carefully.
- Clean the external optics at least every 20 days. Clean the internal optics at least every 30/60 days.

Maintenance Schedule:

To make sure that the fixture is running well and has less failures and higher performance, longer life time, safer running, the fixture should be checked and maintained periodically. Below chart is for your reference.

	Part Description	750hrs	1500hrs	2250hrs	3000hrs	
FIXTURE	Lamp	R/A	R/A	R/A	R/A	
	HEAD	Radiator	C	C	C	C
		Color wheel module	C	C	C	C
		Lens	C	C	C	C
		Optical module	C	C	C	C
		Zoom focus module	C/L	C/L	C/L	C/L
BASE	Radiator	C	C	C	C	
	Tilt belt	A	A	A	A	
	Pan belt	A	A	A	A	

1. Safety Instruction



WARNING

Please read the instruction manual carefully which includes important information about the installation, usage and maintenance.

Please keep this User Manual for future consultation. If you sell the unit to another user, be sure that they also receive this instruction manual.

Important:

Damages caused by the disregard of this user manual are not subject to warranty. The dealer will not accept liability for any resulting defects or problems.

- Unpack and check carefully that there is no transportation damage before using the unit.
- The unit is for indoor use only. Use only in a dry location.
- Do install and operate by qualified operator.
- Do not allow children to operate the fixture.
- Use safety chain when fixing the unit. Handle the unit by carrying its base instead of head only.
- The unit must be installed in a location with adequate ventilation, at least 50cm from adjacent surfaces.
- Be sure that no ventilation slots are blocked; otherwise the unit will be overheated.
- Before operating, ensure that the voltage and frequency of power supply matches the power requirements of the unit.
- It's important to ground the yellow/green conductor to earth in order to avoid electric shock.
- Maximum ambient temperature TA: 40°C. Don't operate it when the temperature is higher.
- Don't connect the device to any dimmer pack.
- During initial start-up some smoke or smell may arise. This is a normal process and does not necessarily mean that the device is defective, and it will decrease gradually within 15 minutes.
- Make sure there are no flammable materials close to the unit while operating to avoid fire hazard.
- Examine the power wires carefully; replace them immediately if there is any damage.
- Unit's surface temperature may reach up to 85°C. Don't touch the housing bare-handed during its operation, and allow about 15 minutes for cooling the unit down before replacing bulb or maintenance as it could be very hot.
- Avoid any inflammable liquids, water or metal objects entering the unit. Once it happens, cut off the mains power immediately.

- Do not operate in dirty or dusty environment; do clean the fixture regularly.
- Do not touch any wire during operation as there might be a hazard of electric shock.
- Avoid power wires twist other cables.
- The minimum distance between light output and the illuminated surface must be more than 12 meters.
- Disconnect mains power before fuse/lamp replacement or servicing.
- Replace fuse/lamp only with the same type.
- In the event of serious operating problem, stop using the unit immediately.
- Never turn on and off the unit time after time.
- The housing, the lenses, or the ultraviolet filter must be replaced if they are visibly damaged.
- Do not open the unit as there are no user serviceable parts inside.
- Never try to repair the unit by yourself. Repairs carried out by unskilled people can lead to damage or malfunction. Please contact the nearest authorized technical assistance center if needed.
- Disconnect the mains power if the fixture is has not been used for a long time.
- Do use the original packing materials before transporting it once again.
- To prevent or reduce the risk of electrical shock or fire, do not expose the unit to rain or moisture.
- Hot lamp explosion hazard. Do not open the unit within 15 minutes after switching off.
- Do replace the bulb once it is damaged, deformed or life-expired.
- Do not look directly at the light while the bulb is on.
- Never touch bulb with bare fingers, as it is very hot after using.
- Do not start on the unit without bulb enclosure or when housing is damaged.

2. Technical Specification

◆ Power supply:

AC 230V, 50Hz

◆ Power Consumption:

1357W

◆ Lamp:

OSRAM HTI 1000W/PS

◆ Optical system:

4. Change a new belt (D). Please adjust the tension of the belt properly. Note: do not fix the belt too tight as it is can easily rupture.
5. Reverse the procedures from step 3 to 2.

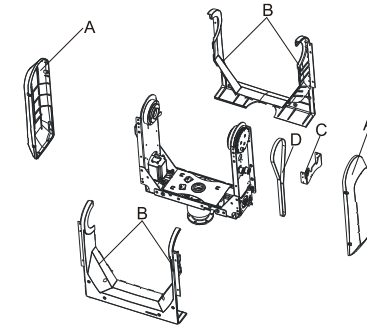

8. Check、 Cleaning and Maintenance Schedule

Check:



Ballast

- A. Do check the fixtures every two months and make sure that all the screws and terminals have been locked firmly to make sure the normal performance of the fixtures. Negligence of check would cause malfunction of the fixture.
- B. As the pictures shown above, please replace the cable or cable joints immediately once they've aged and turned easy to break.

5. Check to see if the DMX cables run near or run alongside high voltage cables that may cause damage or interference to DMX interface circuit.

C. One of the channels is not working well

1. The stepper motor might be damaged or the cable connected to the PCB is broken.
2. The motor's drive IC on the PCB might be out of condition.

D. The lamp is cutting out intermittently

1. The lamp is not working well. Check the mains voltage either too high or too low.
2. Internal temperature may be too high. Check if replacement of fan is needed on the head.

E. If The pan belt is broken

1. Turn off the mains power.
2. Loosen all the screws (AB), open the cover (C).
3. Loosen the screws (D).
4. Unplug all the connect wires over the belt.
5. Change a new belt (E), put the belt around the axis gear and motor gear.
6. Plug all the connect wires back upon the belt.
7. Tighten all the screws.

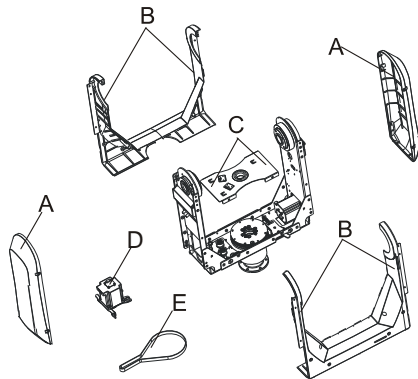

F. If The tilt belt is broken

1. Turn off the mains power.
2. Loosen all the screws (AB).
3. Loosen the screws (C) that fix the bridge.

- High efficient Optical system.
- Delivering extremely powerful output.
- High quality lens.

◆ **Movement:**

- Pan: 540°
- Tilt: 270°
- Pan/Tilt moving speed adjustable
- Automatic Pan/Tilt correction.
- Easy calibration and maintenance by magnetic home positioning.
- Pan/Tilt position lock for transporting protection.

◆ **Dimmer/Shutter:**

- Mechanical dimmer
- Mechanical shutter and adjustable speed strobe effect

◆ **Color wheel:**

- Color wheel: 6 fixed colors
- Rainbow effect in both directions.
- Easy calibration and maintenance by magnetic home positioning

◆ **Cooling:**

- Fan cooling

◆ **Beam Angle:**

- 10° ~ 70°

◆ **Weight:**

- 35.8Kgs

◆ **Dimension:**

- 454 × 427 × 759mm

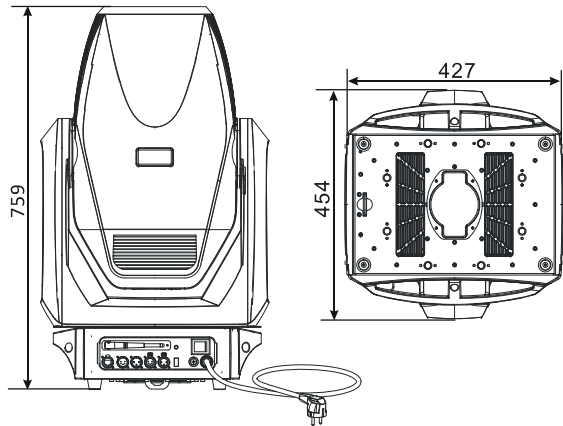

3. Control Panel

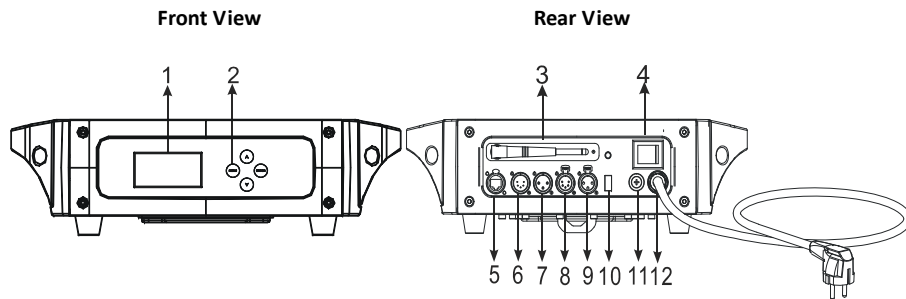

1. FUNCTION DISPLAY:

Shows the various menus and the selected functions;

2. BUTTON:

MENU	To select the programming functions
▲	To go backward in the selected functions
▼	To go forward in the selected functions
ENTER	To confirm the selected functions

3. WIRELESS RECEIVER:

Receives the wireless DMX signal.

	070 – 090 091 – 110 111 – 131 132 – 152 153 – 172 173 – 193 194 – 213 214 – 234 235 – 255	Color Macro 4 Color Macro 5 Color Macro 6 Color Macro 7 Color Macro 8 Color Macro 9 Color Macro 10 Color Macro 11 Color Macro 12
18	0 – 255	ZOOM: Wide → narrow
19	0 – 19 20 – 49 50 – 200 201 – 210 211 – 255	STROBE: Shutter closed, lamp switches to low power Shutter Open Strobe, slow → fast Shutter Open Random strobe
20	0 – 255	DIMMER: Closed (0%) → Open (100%)
21	0 – 255	DIMMER FINE Closed (0%) → Open (100%)

7. Troubleshooting

Following are a few common problems that may occur during operation. Here are some suggestions for easy troubleshooting:

A. The unit does not work, no light and the fan does not work

1. Check the connect power and main fuse.
2. Measure the mains voltage on the main connector.
3. Check the power on LED to see if it can be light up or not.

B. Not responding to DMX controller

1. DMX LED should be on. If not, check DMX connectors, cables to see if they are linked properly.
2. If the DMX LED is on and no response to the channel, check the address settings and DMX polarity.
3. If you have intermittent DMX signal problems, check the pins on connectors or on PCB of the unit or the previous one.
4. Try to use another DMX controller.

	076-089 090 091-104 105-140 141-145 146-150 151-155 156-160 161-165 166-170 171-185 186-211 212-217 218-243 244-247 248-251 252-255	Color 5 → Color 6 Color 6 Color 6 → Open Open Color 1 Color 2 Color 3 Color 4 Color 5 Color 6 Open CW Rotation: Fast → Slow stop CCW Rotation: Slow → Fast Random color: Fast Random color: Medium Random color: Slow
11	0 – 255	CYAN: 0% → 100%
12	0 – 255	MAGENTA: 0% → 100%
13	0 – 255	YELLOW: 0% → 100%
14	0 – 255	CTO: 3200K (0% → 100%)
15	000-021 022-042 043-063 064-085 086-106 107-127 128-148 149-170 171-191 192-212 213-233 234-255	PRESET COLOR: Color 1 Color 2 Color 3 Color 4 Color 5 Color 6 Color 7 Color 8 Color 9 Color 10 Color 11 Color 12
16	0 – 255	CMY SPEED 0%-100%
17	000 – 007 008 – 028 029 – 049 050 – 069	COLOR MACRO Null Color Macro 1 Color Macro 2 Color Macro 3

4. POWER SWITCH:

Turns On/Off the power;

5. ETHERNET:

Transfers fixture's information to a main controller;

6. DMX IN:

DMX 512 operation, use 5-pin XLR cable to link the unit and DMX controller;

7. DMX IN:

DMX 512 link, use 3-pin XLR cable to link the unit and DMX controller;

8. DMX OUT:

DMX 512 operation, use 5-pin XLR cable to link the next units;

9. DMX OUT:

DMX 512 operation, use 3-pin XLR cable to link the next units;

9. BATTERY DISPLAY:

Shows the battery status;

10. USB:

11. FUSE (AC250V/T 15A):

Protect the unit from damage of over voltage or short circuit;

12. POWER:

Connect to the mains supply;

4. Lamp

4.1 Lamp

OSRAM:

1. Because of its high internal pressure, there might be a risk that the Discharge lamp would explode during operation. The lamp emits intense UV radiation which is harmful to the eyes and skin. The high luminance of the arc can cause severe damage to the retina if you take a close look at the lamp.
2. To protect the lamp, always turn off the lamp first (via control panel or DMX controller) and let the unit run at least five minutes to cool down before switching off the mains supply. Never handle the lamp or luminary when it is hot.

3. Do not touch the bulb with bare hands. If this happens, clean the lamp with denatured alcohol and wipe it with a lint free cloth before installation.
4. The lamp generates UV radiation. Never operate the lamp without appropriate shielding.
5. When lining up, the lamp operates at high pressure and there is a slight risk of arc tube rupture. The risk increases with age, temperature and improper handling of the lamp. Do not use the lamp longer than its lifespan.
6. Make sure the lamp is located in the center of the reflector for the best projection.

4.2 Change The Lamp

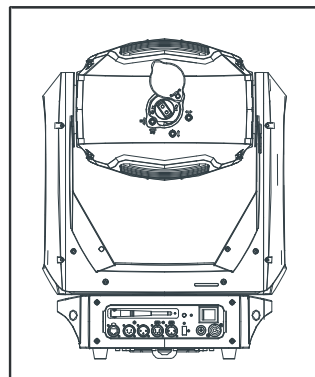
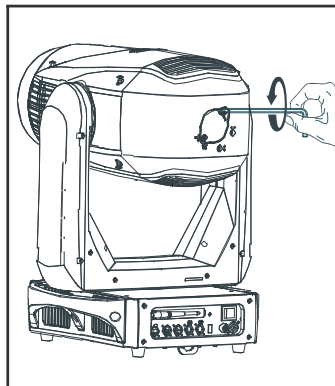
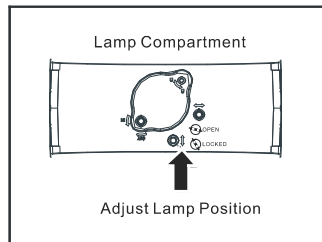
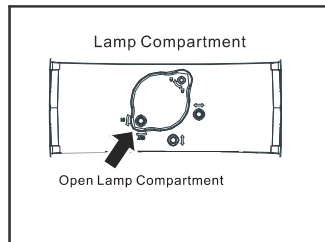

Loosen the screw at the rear side of the fixture and open the lamp compartment cover.

	232 – 239 240 – 247 248 – 255	Macro 29 Macro 30 Macro 31
8	0 – 255	PAN/TILT MACRO SPEED Fast → Slow
9	0 001-014 015 016-029 030 031-044 045 046-059 060 061-074 075 076-089 090 091-104 105-140 141-145 146-150 151-155 156-160 161-165 166-170 171-185 186-211 212-217 218-243 244-247 248-251 252-255	COLOR 1 Open Open to Color 1 Color 1 Color 1 → Color 2 Color 2 Color 2 → Color 3 Color 3 Color 3 → Color 4 Color 4 Color 4 → Color 5 Color 5 Color 5 → Color 6 Color 6 Color 6 → Open Open Color 1 Color 2 Color 3 Color 4 Color 5 Color 6 Open CW Rotation: Fast → Slow stop CCW Rotation: Slow → Fast Random color: Fast Random color: Medium Random color: Slow
10	0 001-014 015 016-029 030 031-044 045 046-059 060 061-074 075	COLOR 2 Open Open to Color 1 Color 1 Color 1 → Color 2 Color 2 Color 2 → Color 3 Color 3 Color 3 → Color 4 Color 4 Color 4 → Color 5 Color 5

6	000 – 069 070 – 079 080 – 089 090 – 099 100 – 109 110 – 129 130 – 139 140 – 149 150 – 159 160 – 169 170 – 189 190 – 199 200 – 209 210 – 229 230 – 239 240 – 255	FUNCTION No Function Enable Blackout X/Y Move Disable Blackout X/Y Move Enable Blackout Color Change Disable Blackout Color Change No Function Lamp On X/Y Reset Effect Reset No Function Effect Reset No Function Reset All No Function Lamp Off No Function
7	000 – 007 008 – 015 016 – 023 024 – 031 032 – 039 040 – 047 048 – 055 056 – 063 064 – 071 072 – 079 080 – 087 088 – 095 096 – 103 104 – 111 112 – 119 120 – 127 128 – 135 136 – 143 144 – 151 152 – 159 160 – 167 168 – 175 176 – 183 184 – 191 192 – 199 200 – 207 208 – 215 216 – 223 224 – 231	PAN/TILT MACRO No Function Macro 1 Macro 2 Macro 3 Macro 4 Macro 5 Macro 6 Macro 7 Macro 8 Macro 9 Macro 10 Macro 11 Macro 12 Macro 13 Macro 14 Macro 15 Macro 16 Macro 17 Macro 18 Macro 19 Macro 20 Macro 21 Macro 22 Macro 23 Macro 24 Macro 25 Macro 26 Macro 27 Macro 28

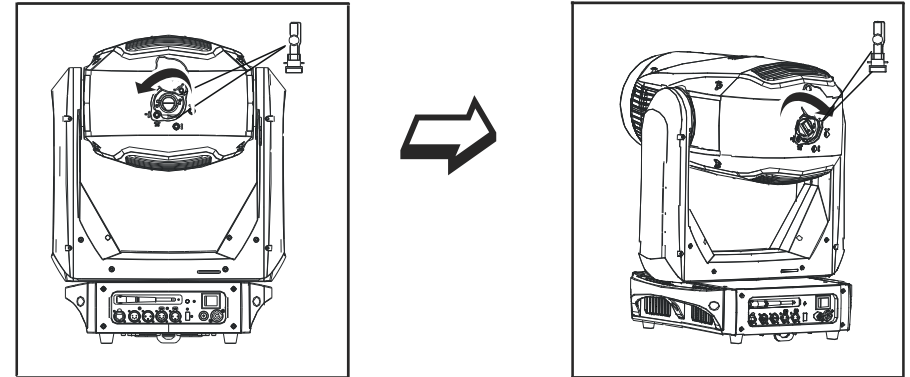

Remove the old lamp and turn the lamp left in order to take the lamp out, put a new lamp that must be the same type as the old one. And then place the new lamp into the lamp holder and turn the lamp right in order to fix. Finally reinstall the lamp compartment cover, fastening it securely before turning on power.

5. How To Set The Unit

5.1 Main Function

Turn on the unit, press the **MENU** button into menu mode, and press the **UP/DOWN** button until the required function is shown on the monitor. Select the function by the **ENTER** button. Use the **UP/DOWN** button to choose the submenu, press the **ENTER** button to store and automatically return to the last menu. Press the **MENU** button or let the unit idle one minute to exit menu mode.

In the event of disconnecting with mains power, press the **UP** button for one minute to enter into menu mode. Press **MENU** button or let the unit idle one minute to exit.

The main functions are shown below:

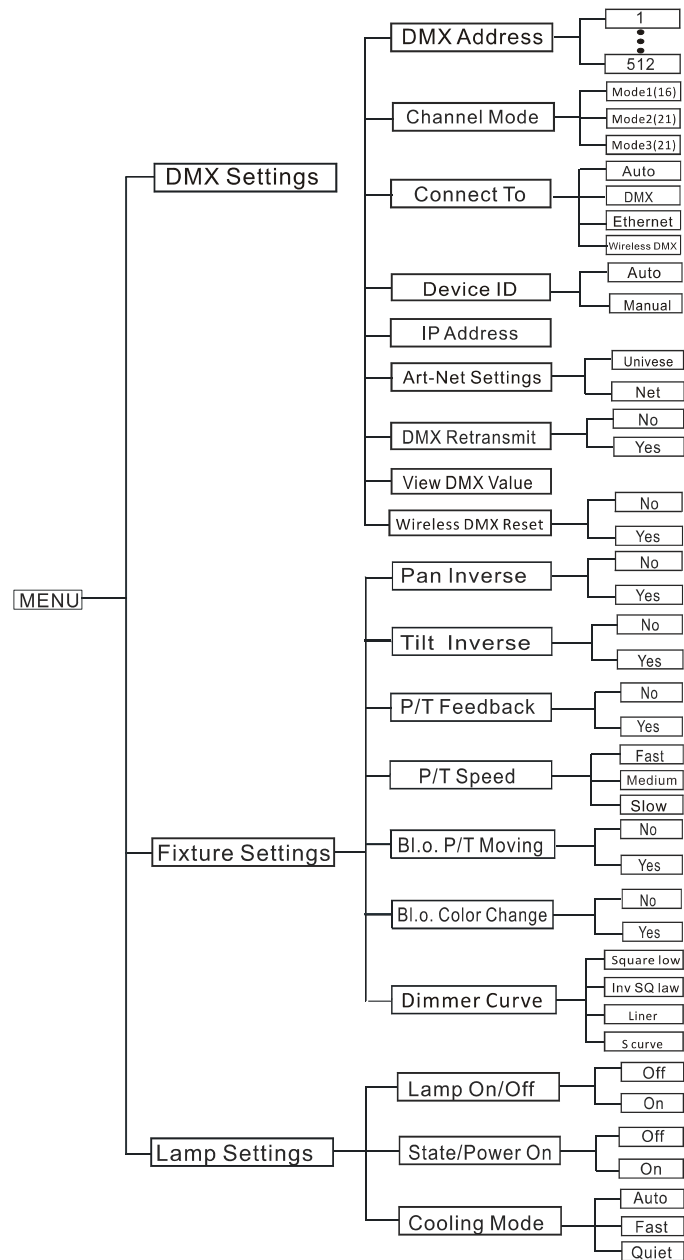

	181 – 185 186 – 214 215 – 243 244 – 255	White CW Rotation: Fast → Slow CCW Rotation Slow → Fast No Function
9	0 – 255	ZOOM: Wide → narrow
10		Null
11		Null
12		Null
13		Null
14		Null
15		Null
16	0 – 255	PAN: 0° → 540°
17	0 – 255	PAN FINE
18	0 – 255	TILT: 0° → 270°
19	0 – 255	TILT FINE
20	0 – 255	PAN/TILT SPEED Fast → Slow
21		Null

21 Channels (Mode 3):

CHANNEL	VALUE	FUNCTION
1	0 – 255	PAN: 0° → 540°
2	0 – 255	PAN FINE
3	0 – 255	TILT: 0° → 270°
4	0 – 255	TILT FINE
5	0 – 255	PAN/TILT SPEED Fast → Slow

	050 – 072 073 – 079 080 – 099 100 – 119 120 – 127 128 – 187 188 – 190 191 – 196 197 – 202 203 – 207 208 – 217 218 – 227 228 – 237 238 – 247 248 – 255	Shutter Fast to Slow Open Pulse Open Fast to Slow Pulse Close Fast to Slow Open Random Shutter Open Random Pulse Open Fast to Slow Random Pulse Close Fast to Slow Open Reset Open Lamp On Open Lamp Off
2	0 – 255	DIMMER: Closed (0%) → Open (100%)
3	0 – 255	CYAN: 0% → 100%
4	0 – 255	MAGENTA: 0% → 100%
5	0 – 255	YELLOW: 0% → 100%
6	0 – 255	CTO: 3200K (0% → 100%)
7	000 – 128 129 – 160 161 – 165 166 – 170 171 – 175 176 – 180 181 – 185 186 – 214 215 – 243 244 – 247 248 – 251 252 – 255	COLOR 1 Color Index White Color 1 Color 2 Color 3 Color 4 White CCW Rotation: Fast → Slow CW Rotation Slow → Fast Random Color(Fast) Random Color(Medium) Random Color(Slow)
8	000 – 128 129 – 160 161 – 165 166 – 170 171 – 175 176 – 180	COLOR 2 Color Index White Color 1 Color 2 Color 3 Color 4

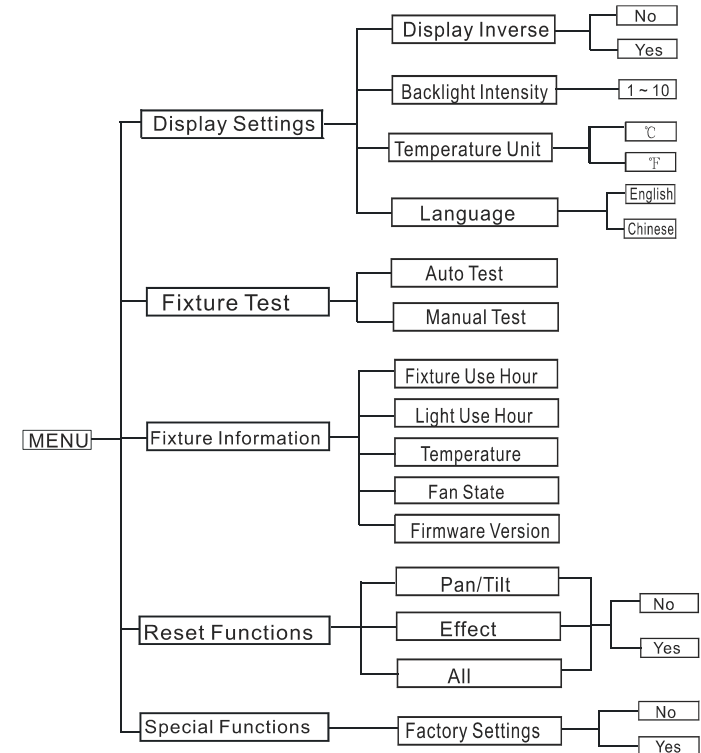

DMX Settings

To select **DMX Settings**, press the **ENTER** button to confirm, use the **UP/DOWN** button to select **DMX Address**, **Channel Mode**, **Connect To**, **Device ID**、**IP Address**、**Art-Net Setting**、**DMX Retransmit**、**View DMX Value** or **Wireless DMX Reset**.

DMX Address

To select **DMX Address**, press the **ENTER** button to confirm. Use the **UP/DOWN** button to adjust the address from **1** to **512**, press the **ENTER** button to store. Press the **MENU** button back to the last menu or let the unit idle one minute to exit menu mode.

Channel Mode

To select **Channel Mode**, press the **ENTER** button to confirm. Use the **UP/DOWN** button to select

16 Channel, 21 Channel or 21 Channel mode, press the **ENTER** button to store. Press the **MENU** button back to the last menu or let the unit idle one minute to exit menu mode.

Connect To

To select **Connect To**, press the **ENTER** button to confirm. Use the **UP/DOWN** button to select **Auto, DMX, Ethernet** or **Wireless DMX**, press the **ENTER** button to store. Press the **MENU** button back to the last menu or let the unit idle one minute to exit menu mode.

Device ID

To select **Device ID**, press the **ENTER** button to confirm. Use the **UP/DOWN** button to select **Auto** or **Manual**, press the **ENTER** button to store. Press the **MENU** button back to the last menu or let the unit idle one minute to exit menu mode.

IP Address

To select **IP Address**, press the **ENTER** button to confirm and the display will show the current IP Address of the unit. To go back to the functions press the **MENU** button again. Hold and press the **MENU** button about one second or wait for one minute to exit the menu mode.

Art-net Setting

To select **Art-net Setting**, press the **ENTER** button to confirm. Use the **UP/DOWN** button to select **Universe** or **Net**, press the **ENTER** button to store. Press the **MENU** button back to the last menu or let the unit idle one minute to exit menu mode.

DMX Retransmit

To select **DMX Retransmit**, press the **ENTER** button to confirm. Use the **UP/DOWN** button to select **No** (normal) or **Yes** (DMX Retransmit), press the **ENTER** button to store. Press the **MENU** button back to the last menu or let the unit idle one minute to exit menu mode.

View DMX Value

To select **View DMX Value**, press the **ENTER** button to confirm. Use the **UP/DOWN** button to view the DMX channel value. Press the **MENU** button back to the last menu or let the unit idle one minute to exit menu mode.

Wireless DMX Reset

To select **Wireless DMX Reset**, press the **ENTER** button to confirm. Use the **UP/DOWN** button to select **No** (normal) or **Yes** (Wireless DMX Reset), press the **ENTER** button to store. Press the **MENU**

14	000-021	PRESET COLOR: Color 1 Color 2 Color 3 Color 4 Color 5 Color 6 Color 7 Color 8 Color 9 Color 10 Color 11 Color 12
	022-042	
	043-063	
	064-085	
	086-106	
	107-127	
	128-148	
	149-170	
	171-191	
	192-212	
	213-233	
	234-255	
15	0 – 255	ZOOM: Wide → narrow
16	000 – 069	FUNCTION: No Function Enable Blackout X/Y Move Disable Blackout X/Y Move Enable Blackout Color Change Disable Blackout Color Change No Function Lamp On X/Y Reset Effect Reset No Function Effect Reset No Function Reset All No Function Lamp Off No Function
	070 – 079	
	080 – 089	
	090 – 099	
	100 – 109	
	110 – 129	
	130 – 139	
	140 – 149	
	150 – 159	
	160 – 169	
	170 – 189	
	190 – 199	
	200 – 209	
	210 – 229	
230 – 239		
240 – 255		

21 Channels (Mode 2):

CHANNEL	VALUE	FUNCTION
1	000 – 019	SHUTTER Off Open
	020 – 049	

	161-165 166-170 171-185 186-211 212-217 218-243 244-247 248-251 252-255	Color 5 Color 6 Open CW Rotation: Fast → Slow stop CCW Rotation: Slow → Fast Random color: Fast Random color: Medium Random color: Slow
9	0 001-014 015 016-029 030 031-044 045 046-059 060 061-074 075 076-089 090 091-104 105-140 141-145 146-150 151-155 156-160 161-165 166-170 171-185 186-211 212-217 218-243 244-247 248-251 252-255	COLOR 2 Open Open to Color 1 Color 1 Color 1 → Color 2 Color 2 Color 2 → Color 3 Color 3 Color 3 → Color 4 Color 4 Color 4 → Color 5 Color 5 Color 5 → Color 6 Color 6 Color 6 → Open Open Color 1 Color 2 Color 3 Color 4 Color 5 Color 6 Open CW Rotation: Fast → Slow stop CCW Rotation: Slow → Fast Random color: Fast Random color: Medium Random color: Slow
10	0 – 255	CYAN: 0% → 100%
11	0 – 255	MAGENTA: 0% → 100%
12	0 – 255	YELLOW: 0% → 100%
13	0 – 255	CTO: 3200K (0% → 100%)

button back to the last menu or let the unit idle one minute to exit menu mode.

Fixture Settings

To select **Fixture Settings**, press the **ENTER** button to confirm, use the **UP/DOWN** button to select **Pan Inverse**, **Tile Inverse**, **P/T Feedback**, **P/T Speed**, **BL.O. P/T Moving**, **BL.O. Color Change** or **Dimmer Curve**.

Pan Inverse

To select **Pan Inverse**, press the **ENTER** button to confirm. Use the **UP/DOWN** button to select **No** (normal) or **Yes** (pan inverse), press the **ENTER** button to store. Press the **MENU** button back to the last menu or let the unit idle one minute to exit menu mode.

Tilt Inverse

To select **Tilt Inverse**, press the **ENTER** button to confirm. Use the **UP/DOWN** button to select **No** (normal) or **Yes** (tilt inverse), press the **ENTER** button to store. Press the **MENU** button back to the last menu or let the unit idle one minute to exit menu mode.

P/T Feedback

To select **P/T Feedback**, press the **ENTER** button to confirm. Use the **UP/DOWN** button to select **No** (Pan or tilt's position will not feedback while out of step) or **Yes** (Feedback while pan/tilt out of step), press the **ENTER** button to store. Press the **MENU** button back to the last menu or let the unit idle one minute to exit menu mode.

P/T Speed

To select **P/T Speed**, press the **ENTER** button to confirm. Use the **UP/DOWN** button to select **Fast**, **Medium** or **Slow**, press the **ENTER** button to store. Press the **MENU** button back to the last menu or let the unit idle one minute to exit menu mode.

BL.O. P/T Moving —Blackout while pan/tilt moving

To select **BL.O. P/T Moving**, press the **ENTER** button to confirm. Use the **UP/DOWN** button to select **No** (normal while pan/tilt moving) or **Yes** (blackout while pan/tilt moving), press the **ENTER** button to store. Press the **MENU** button back to the last menu or let the unit idle one minute to exit menu mode.

BL.O. Color Change — Blackout while color changing

To select **BL.O. Color Change**, press the **ENTER** button to confirm. Use **UP/DOWN** button to select

No (normal while changing color) or **Yes** (blackout while color changing), press the **ENTER** button to store. Press the **MENU** button back to the last menu or let the unit idle one minute to exit menu mode.

Dimmer Curve

To select **Dimmer Curve**, press the **ENTER** button to show the **DIMMER CURVE** on the display, use the **UP/DOWN** button to select **Square Law**, **Inverse Squ.**, **Linear**, or **S-curve**. Once selected, press the **ENTER** button to store. Press the **MENU** button back to the last menu or let the unit idle one minute to exit menu mode.

Dimmer Modes:

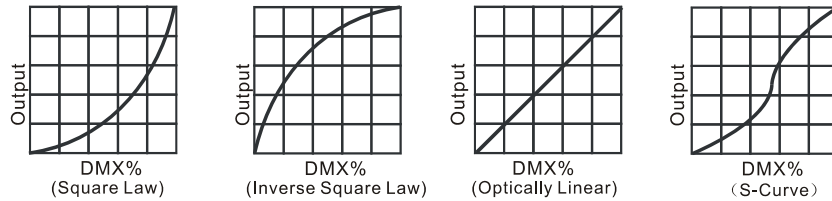

Square Law: Light intensity control is finer at low levels and coarser at high levels.

Inverse Square Law: Light intensity control is coarser at low levels and finer at high levels.

Linear: The increase in light intensity appears to be linear as DMX value is increased.

S-cure: Light intensity control is finer at low levels and high levels and coarser at medium levels.

Lamp Settings

To select **Lamp Settings**, press the **ENTER** button to confirm, use the **UP/DOWN** button to select **Lamp On/Off**, **State/Power on** or **Cooling Mode**.

Lamp On/Off

To select **Lamp On/Off**, press the **ENTER** button to confirm. Use the **UP/DOWN** button to select **Off** (lamp off) or **On** (lamp on), press the **ENTER** button to store. Press the **MENU** button back to the last menu or let the unit idle one minute to exit menu mode.

State/Power On

To select **State/Power On**, press the **ENTER** button to confirm. Use the **UP/DOWN** button to select **Off** (Lamp off while power on) or **On** (Lamp on while power on), press the **ENTER** button to store. Press the **MENU** button back to the last menu or let the unit idle one minute to exit menu mode.

6.4 DMX Control

16Channels (Mode 1):

CHANNEL	VALUE	FUNCTION
1	0 – 255	PAN: 0° → 540°
2	0 – 255	PAN FINE
3	0 – 255	TILT: 0° → 270°
4	0 – 255	TILT FINE
5	0 – 255	PAN/TILT SPEED Fast → Slow
6	000 – 019 020 – 049 050 – 200 201 – 210 211 – 255	STROBE: Shutter closed, lamp switches to low power Shutter Open Strobe, slow → fast Shutter Open Random strobe
7	0 – 255	DIMMER: Closed (0%) → Open (100%)
8	0 001-014 015 016-029 030 031-044 045 046-059 060 061-074 075 076-089 090 091-104 105-140 141-145 146-150 151-155 156-160	COLOR 1 Open Open to Color 1 Color 1 Color 1 → Color 2 Color 2 Color 2 → Color 3 Color 3 Color 3 → Color 4 Color 4 Color 4 → Color 5 Color 5 Color 5 → Color 6 Color 6 Color 6 → Open Open Color 1 Color 2 Color 3 Color 4

3. The DMX output and input connectors are pass-through to maintain the DMX circuit, when one of the units' power is disconnected.
4. Each lighting unit needs to have a DMX address to receive the data by the controller. The address number is between 0-511 (usually 0 & 1 are equal to 1).
5. The end of the DMX 512 system should be terminated to reduce signal errors.
6. 3 pin XLR connectors are more popular than 5 pins XLR.
 - 3 pin XLR: Pin 1: GND, Pin 2: Negative signal (-), Pin 3: Positive signal (+)
 - 5 pin XLR: Pin 1: GND, Pin 2: Negative signal (-), Pin 3: Positive signal (+), Pin4, Pin5 not used.

6.2 Channel Mode Setting

Enter menu mode, select **DMX Functions**, press the **ENTER** button to confirm, use the **UP/DOWN** button to select **Mode**, press the **ENTER** button to confirm, present channel mode will blink on the display, use the **UP/DOWN** button to select **26 Channel**, **34 Channel**, **28 Channel**, **24 Channel** or **21 Channel** Mode, and press the **ENTER** button to store. Press the **MENU** button back to the last menu or let the unit idle one minute to exit menu mode.

6.3 Address Setting

If you use a universal DMX controller to control the units, you have to set DMX address from 1 to 512 so that the units can receive DMX signal.

Press the **MENU** button to enter menu mode, select **DMX Functions**, press the **ENTER** button to confirm, use the **UP/DOWN** button to select **DMX Address**, press the **ENTER** button to confirm, the present address will blink on the display. Use the **UP/DOWN** button to adjust the address from 1 to 512, press the **ENTER** button to store. Press the **MENU** button back to the last menu or let the unit idle one minute to exit menu mode.

Please refer to the following diagram to set the address for the first 4 units.

Channel mode	Unit 1 Address	Unit 2 Address	Unit 3 Address	Unit 4 Address
16 channels	1	17	33	49
21 channels	1	22	43	64
21 channels	1	22	43	64

Cooling Mode

To select **Cooling Mode**, press the **ENTER** button to confirm. Use the **UP/DOWN** button to select **Auto**, **Fast** or **Quiet**, press the **ENTER** button to store. Press the **MENU** button back to the last menu or let the unit idle one minute to exit menu mode.

Display Settings

To select **Display Settings**, press the **ENTER** button to confirm, use the **UP/DOWN** button to select **Display Inverse**, **Backlight Intensity** or **Temperature Unit**.

Display Inverse

To select **Display Inverse**, press the **ENTER** button to confirm. Use the **UP/DOWN** button to select **No** (normal) or **Yes** (display inverse), press the **ENTER** button to store. Press the **MENU** button back to the last menu or let the unit idle one minute to exit menu mode.

Backlight Intensity

To select **Backlight Intensity**, press the **ENTER** button to confirm. Use the **UP/DOWN** button to adjust the value from **1** to **10**, press the **ENTER** button to store. Press the **MENU** button back to the last menu or let the unit idle one minute to exit menu mode.

Temperature Unit

To select **Temperature Unit**, press the **ENTER** button to confirm. Use the **UP/DOWN** button to select **°C** or **°F**, press the **ENTER** button to store. Press the **MENU** button back to the last menu or let the unit idle one minute to exit menu mode.

Language

To select **Language**, press the **ENTER** button to confirm. Use the **UP/DOWN** button to select **English** or **Chinese**, press the **ENTER** button to store. Press the **MENU** button back to the last menu or let the unit idle one minute to exit menu mode.

Fixture Test

To select **Fixture Test**, press the **ENTER** button to confirm, use the **UP/DOWN** button to select **Auto Test** or **Manual Test**

Auto Test

To select **Auto Test**, press the **ENTER** button to confirm, the unit will run built-in programs to

automatically test pan, tilt, shutter, color, gobo, gobo rotation, prism, prism rotation, focus, dimmer and lamp on/off. Press the **MENU** button back to the last menu or exit menu mode after auto test.

Manual Test

To select **Manual Test**, press the **ENTER** button to confirm, the present channel will show on the display, use the **UP/DOWN** button to select channel, press the **ENTER** button to confirm, then use the **UP/DOWN** button to adjust the value, press the **ENTER** button to store, the fixture will run as the channel value indicates. Press the **MENU** button back to the last menu or exit menu mode idling one minute.

(All channels value will become 0 after exiting Manual Test menu)

Fixture Information

To select **Fixture Information**, press the **ENTER** button to confirm, use the **UP/DOWN** button to select **Fixture Use Hour, Light Use Hour, Temperature, Fan State or Firmware Version**.

Fixture Use Hour

Select **Fixture Use Hour**, press the **ENTER** button to confirm, fixture use time will show on the display, press the **MENU** button to exit.

Light Use Hour

To select **Light Use Hour**, press the **ENTER** button to confirm, lamp on time will show on the display, press the **ENTER** button to confirm, use the **UP/DOWN** button to select **Exit or Reset Time**, press the **ENTER** button to confirm. Press the **MENU** button back to the last menu or exit menu mode idling one minute.

Temperature

Select **Temperature**, press the **ENTER** button to confirm, fixture state will show on the display, press the **MENU** button to exit.

Fan State

Select **Fan State**, press the **ENTER** button to confirm, fixture state will show on the display, press the **MENU** button to exit.

Firmware Version

To select **Firmware Version**, press the **ENTER** button to confirm, firmware version will show on the

CPU-B Error, CPU-C Error, CPU-D Error

They appear when board P.C or some wires are damaged.

Pan Reset Error, Pan Encode Error, Tilt Reset Error, Tilt Encode Error, Shutter Reset Fail, Dimmer Reset Fail, Color Reset Fail, , Gobo Reset Fail, Focus Reset fail.

They may appear when turning on or resetting the unit, for some parts such as board P.C are damaged. Please contact the qualified maintenance.

6. Control By Universal DMX Controller

6.1 DMX Connections

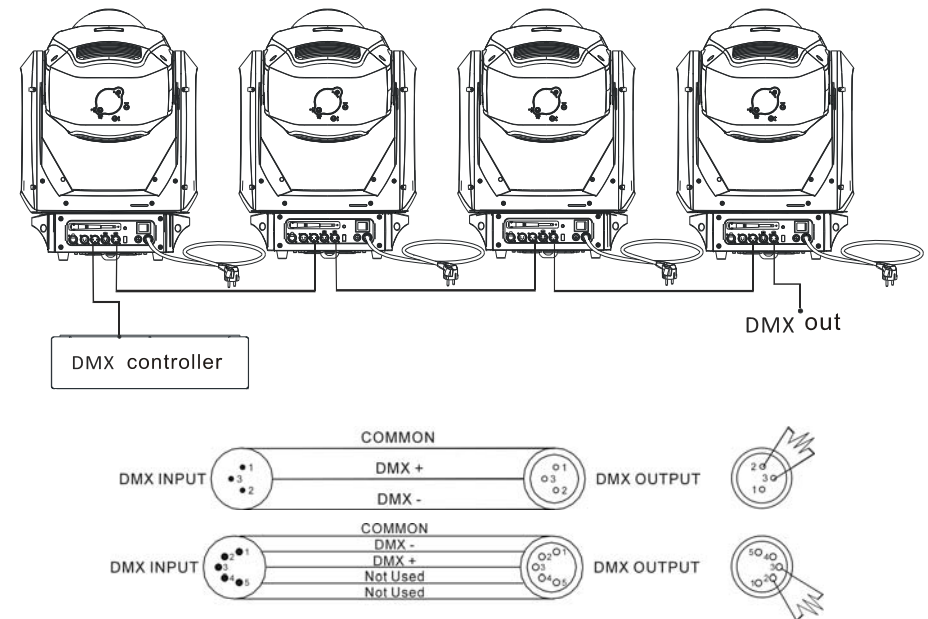

1. At last unit, the DMX cable has to be terminated with a terminator. Solder a 120-ohm 1/4W resistor between pin 2(DMX-) and pin 3(DMX+) into a 3-pin XLR-plug and plug it in the DMX-output of the last unit.
2. Connect the unit together in a “daisy chain” by XLR plug cable from the output of the unit to the input of the next unit. The cable cannot be branched or split to a “Y” cable. DMX 512 is a very high-speed signal. Inadequate or damaged cables, soldered joints or corroded connectors can easily distort the signal and shut down the system.

Magenta - Magenta home position adjustment

Enter offset mode, select **Magenta** press the **ENTER** button to confirm. Use the **UP/DOWN** button to offset the value from **0** to **255**, press the **ENTER** button to store. Press the **MENU** button to exit.

Yellow - Yellow home position adjustment

Enter offset mode, select **Yellow** press the **ENTER** button to confirm. Use the **UP/DOWN** button to offset the value from **0** to **255**, press the **ENTER** button to store. Press the **MENU** button to exit.

CTO- CTO home position adjustment

Enter offset mode, select **CTO**, press the **ENTER** button to confirm. Press the **ENTER** button to store. Press the **MENU** button to exit.

5.3 Error Information

Lamp Startup Fail

It appears when there is no lamp or some wires are damaged.

Temperature Sense Error

It appears when temperature check board is damaged.

Lamp Too Hot Power Off

It appears when temperature is detected higher than 110°C. Check if the unit is properly ventilated, or fans or temperature check board may is damaged.

Lamp Too Hot Low Power

It appears when temperature is detected higher than 105°C, the unit will run on a low power level.

Maintenance Fixture

It appears when the maintenance remaining time becomes 0S, please enter menu mode and reset the time.

Lamp On Over 700 Hour

It appears when the lamp has been on over 700 hours, please turn off the lamp.

Memory Initial Fail

It appears when the memory IC is damaged.

display, press the **MENU** button back to exit.

Reset Functions

To select **Reset Function**, press the **ENTER** button to confirm, use the **UP/DOWN** button to select **Pan/Tilt, Effect** or **All**.

Pan/Tilt — Reset Pan/Tilt

To select **Pan/Tilt**, press the **ENTER** button to confirm, use the **UP/DOWN** button to select **Yes** (the unit will run built-in program to reset pan and tilt to their home positions) or **No**, press the **ENTER** button to store. Press the **MENU** button back to the last menu or let the unit idle one minute to exit menu mode.

Effect

To select **Effect**, press the **ENTER** button to confirm, use the **UP/DOWN** button to select **Yes** (the unit will run built-in program to reset shutter to their home positions) or **No**, and press the **ENTER** button to store. Press the **MENU** button to exit.

All — Reset All

To select **All**, press the **ENTER** button to confirm, use the **UP/DOWN** button to select **Yes** (the unit will run built-in program to reset all motors to their home positions) or **No**, press **ENTER** button to store. Press the **MENU** button to exit.

Special Functions

To select **Special Functions**, press the **ENTER** button to confirm, and select **Factory Settings**.

Factory Settings

To Select **Factory Setting**, Use the **UP/DOWN** button to select **Yes** (the fixture will reset to factory settings) or **No**(Normal), press the **ENTER** button to confirm. Press the **MENU** button back to the last menu or exit menu mode idling one minute.

5.2 Home Position Adjustment

Press the **MENU** button into menu mode, then press and hold the **ENTER** button for about 3 seconds

into offset mode to adjust the home position. Select the function by the **ENTER** button. Use the **UP/DOWN** button to select the submenu, press the **ENTER** button to store and automatically return to the last menu. Press the **MENU** button to exit.

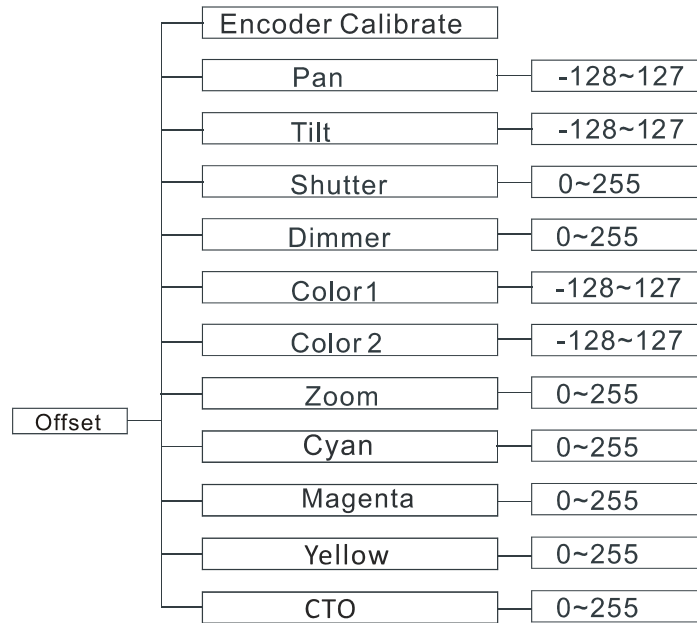

Encoder Calibrate- Encoder Calibrate home position adjustment

Enter offset mode, select **Encoder Calibrate**, press the **ENTER** button to confirm. Use the **UP/DOWN** button to offset the **Encoder Calibrate**, press the **ENTER** button to store. Press the **MENU** button to exit.

Pan - pan home position adjustment

Enter offset mode, select **Pan**, press the **ENTER** button to confirm. Use the **UP/DOWN** button to offset the value from **-128** to **127**, press the **ENTER** button to store. Press the **MENU** button to exit.

Tilt - Tilt home position adjustment

Enter offset mode, select **Tilt**, press the **ENTER** button to confirm. Use the **UP/DOWN** button to offset

the value from **-128** to **127**, press the **ENTER** button to store. Press the **MENU** button to exit.

Shutter - Shutter home position adjustment

Enter offset mode, select **Shutter**, press the **ENTER** button to confirm. Use the **UP/DOWN** button to offset the value from **0** to **255**, press the **ENTER** button to store. Press the **MENU** button to exit.

Dimmer - Dimmer home position adjustment

Enter offset mode, select **Dimmer**, press the **ENTER** button to confirm. Use the **UP/DOWN** button to offset the value from **0** to **255**, press the **ENTER** button to store. Press the **MENU** button to exit.

Color 1 - Color home position adjustment

Enter offset mode, select **Color 1**, press the **ENTER** button to confirm. Use the **UP/DOWN** button to offset the value from **-128** to **127**, press the **ENTER** button to store. Press the **MENU** button to exit.

Color 2 – Gobo1 home position adjustment

Enter offset mode, select **Color 2**, press the **ENTER** button to confirm. Use the **UP/DOWN** button to offset the value from **-128** to **127**, press the **ENTER** button to store. Press the **MENU** button to exit.

Iris- Iris home position adjustment

Enter offset mode, select **Iris**, press the **ENTER** button to confirm. Use the **UP/DOWN** button to offset the value from **0** to **255**, press the **ENTER** button to store. Press the **MENU** button to exit.

Zoom - Zoom home position adjustment

Enter offset mode, select **Zoom** press the **ENTER** button to confirm. Use the **UP/DOWN** button to offset the value from **0** to **255**, press the **ENTER** button to store. Press the **MENU** button to exit.

Cyan - Cyan home position adjustment

Enter offset mode, select **Cyan** press the **ENTER** button to confirm. Use the **UP/DOWN** button to offset the value from **0** to **255**, press the **ENTER** button to store. Press the **MENU** button to exit.